

STAX

Wire modules in order as shown on the diagram

Maximum Amperage per circuit: 16 Amps @120V

STAX Boost Power Continuation Cable found in (Yellow Labeled bag). Required after the first 12 modules per display face.

STAX Controller Cable Kit found in (Red Labeled bag). One cable kit per display face. Includes one Primary Controller Power Cable and one 1st Module Power / Data Cable

Multiple circuits can be connected together and share a breaker. Multiple circuits may share the same neutrals. Please follow your local NEC Codes

Master Display

Circuit	Max Watts	Avg Watts	Amps @120V
1	3402	1659	13.8
2			
3			
Total	3402	1659	13.8

Slave Display

Circuit	Max Watts	Avg Watts	Amps @120V
4	3402	1659	13.8
5			
6			
Total	3402	1659	13.8

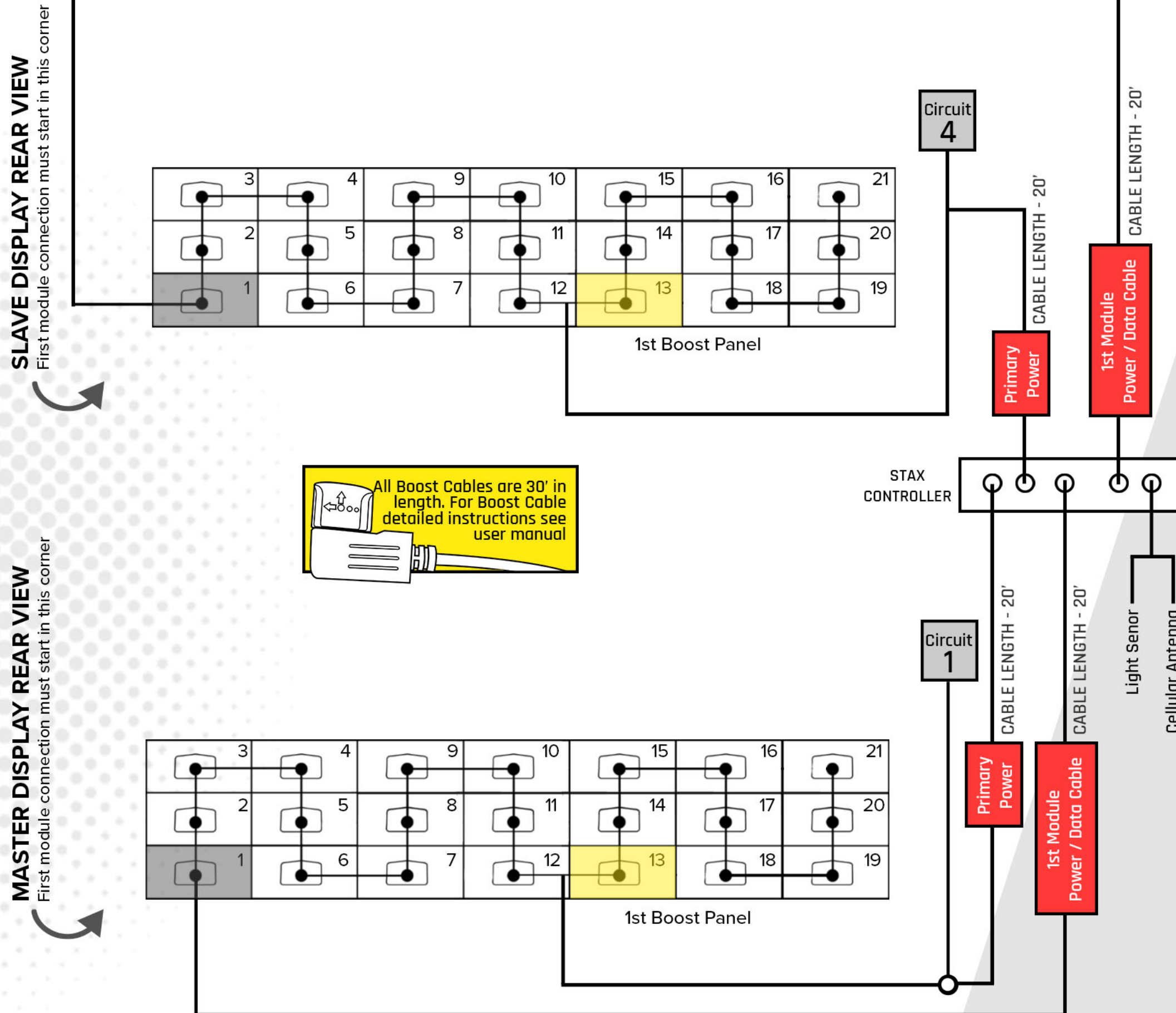

SLAVE DISPLAY REAR VIEW
First module connection must start in this corner

MASTER DISPLAY REAR VIEW
First module connection must start in this corner

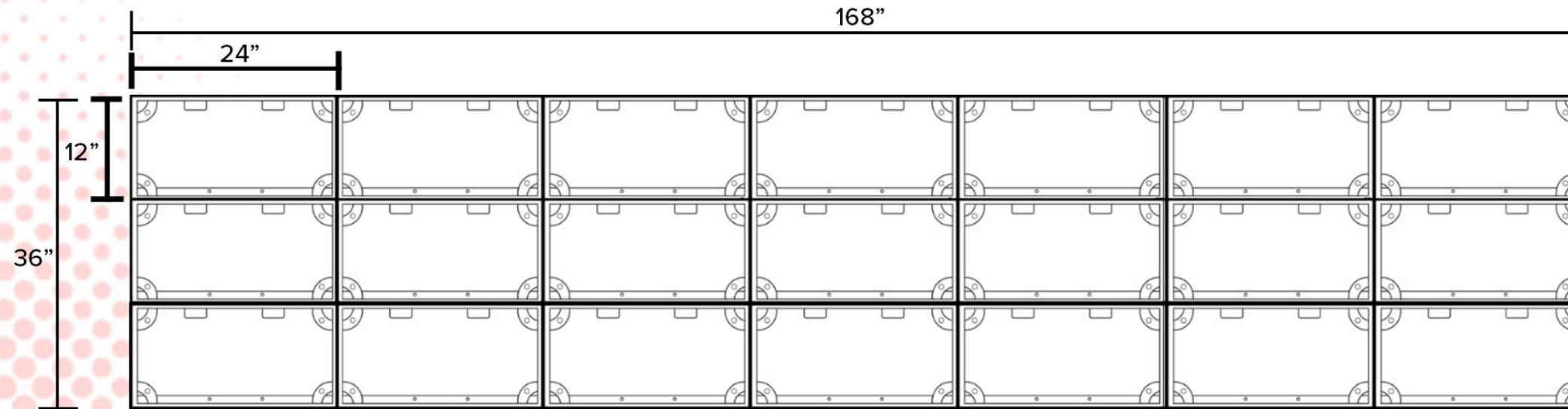

Must lift final assembled sign with a minimum of two lifting points. 330 maximum lbs per lifting pin.

Parts List	Single Face	Double Face
Module	21	42
Controller	1	1
Controller Cable Kit	1	2
Boost Power Cable	1	2

AND

Option 1: Single Frame Assembly	Single Face	Double Face
1' x 2' Frame	21	42
1' x 2' Frame Door (Optional)	21	42

OR

Option 2: Mixed Frame Assembly	Single Face	Double Face
1' x 2' Frame	9	18
1' x 2' Frame Door (Optional)	9	18
2' x 4' Frame	3	6
2' x 4' Frame Door (Optional)	6	12

MASTER DISPLAY REAR VIEW

SHACKLE ATTACHMENT

The shackle cables should connect to the lifting pins at an angle of 30 degrees or less to prevent damage to the cabinet frame. Spreader bar should be used when three or more lifting pins are required per face.

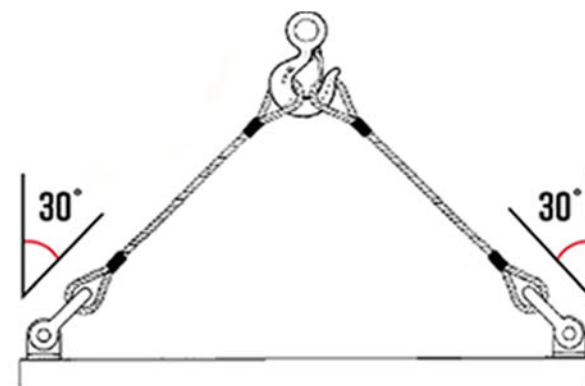

Display Weight	Maximum lbs	Maximum lbs per lifting pin	Number of Pins Per Face
Single Face	354.9	330	2
Double Face	709.8	N/A	N/A