

# STAX

Wire modules in order as shown on the diagram

Maximum Amperage per circuit: 16 Amps @120V

STAX Boost Power Continuation Cable found in (Yellow Labeled bag). Required after the first 12 modules per display face.

STAX Controller Cable Kit found in (Red Labeled bag). One cable kit per display face. Includes one Primary Controller Power Cable and one 1st Module Power Data Cable

Multiple circuits can be connected together and share a breaker. Multiple circuits may share the same neutrals. Please follow your local NEC Codes

Master Display

Circuit	Max Watts	Avg Watts	Amps @120V
1	3888	1896	15.8
2			
3			
Total	3888	1896	15.8

Slave Display

Circuit	Max Watts	Avg Watts	Amps @120V
4	3888	1896	15.8
5			
6			
Total	3888	1896	15.8

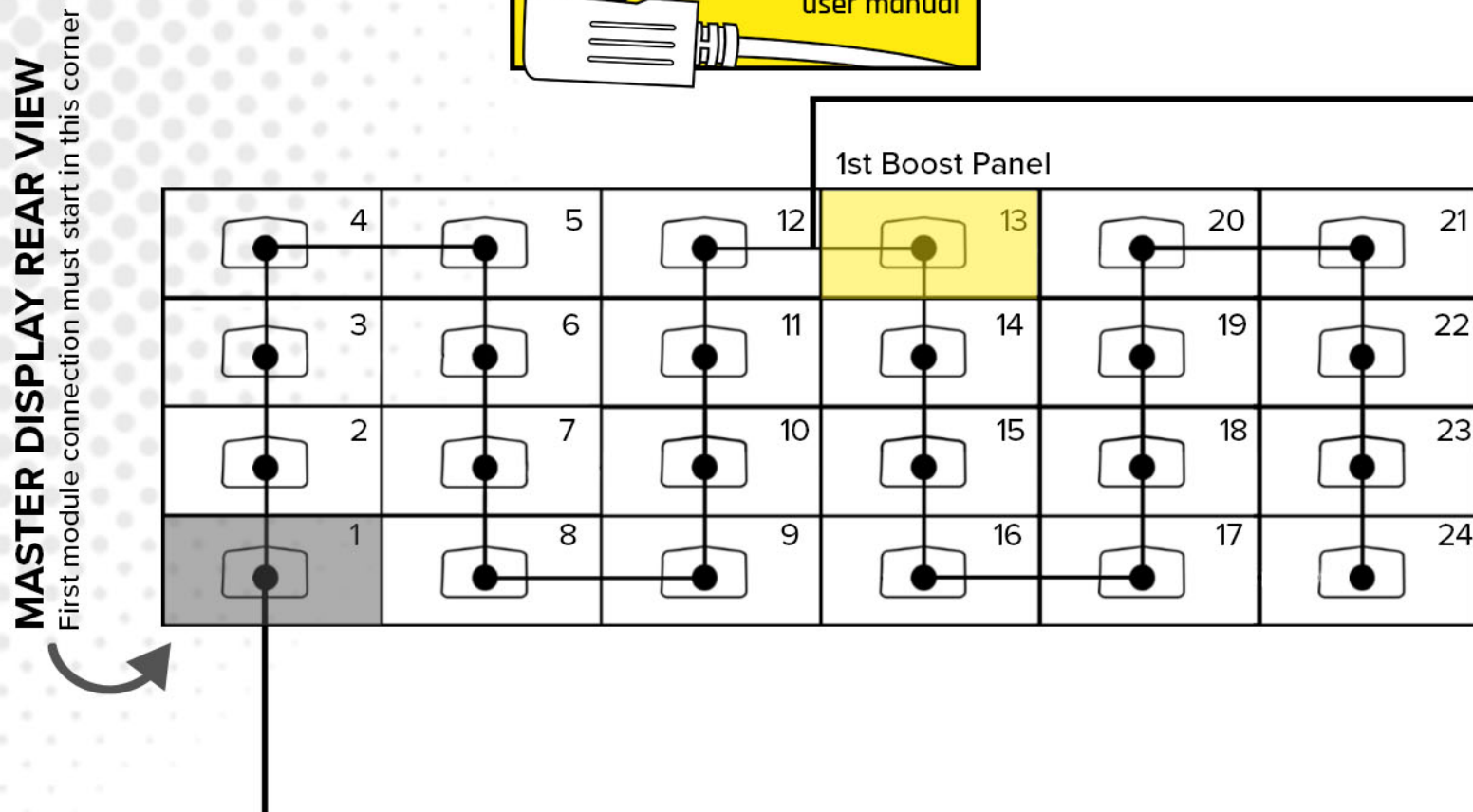
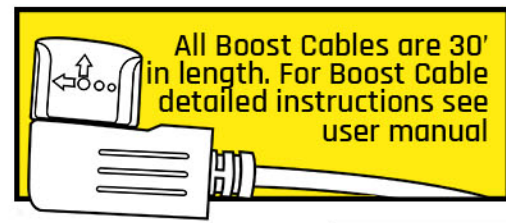
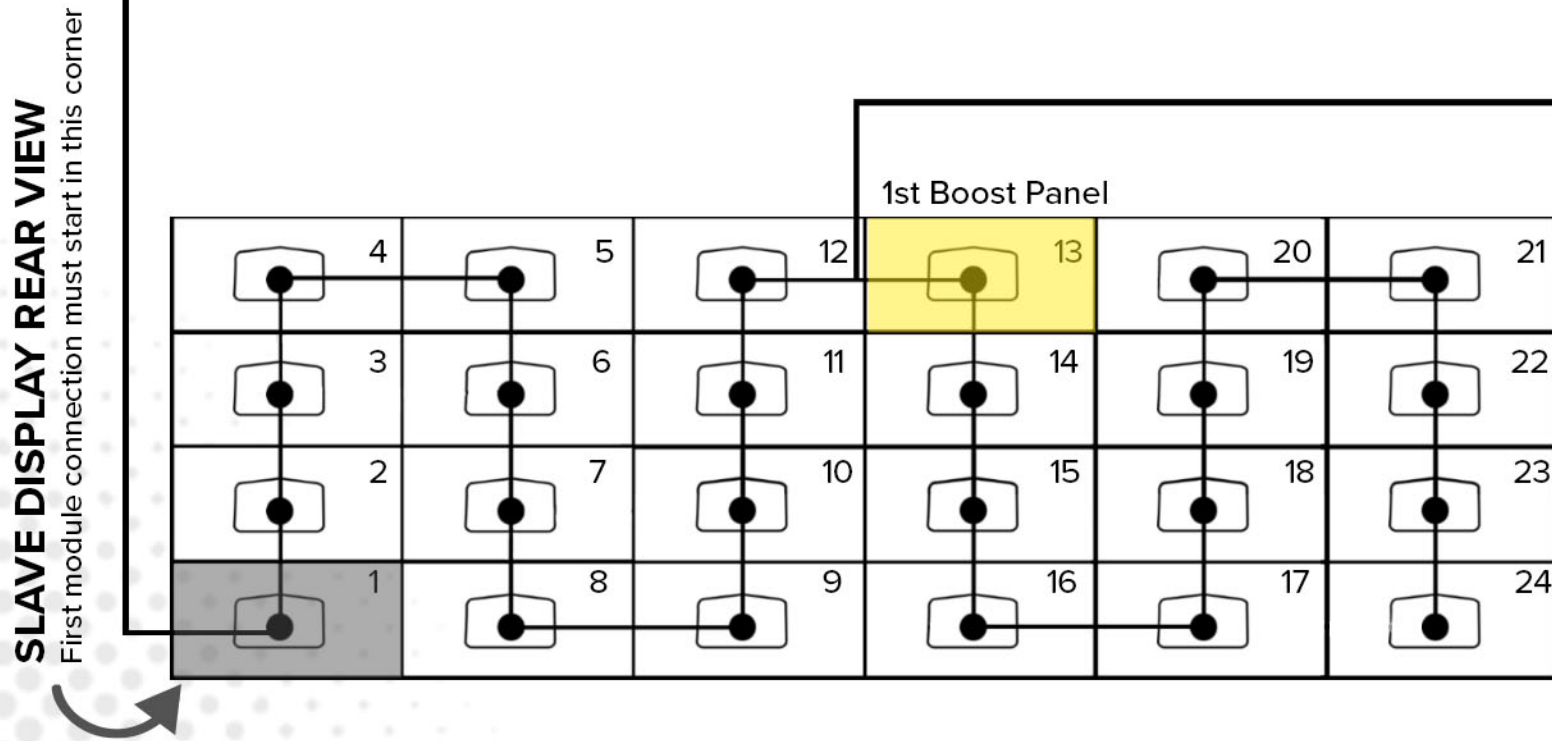

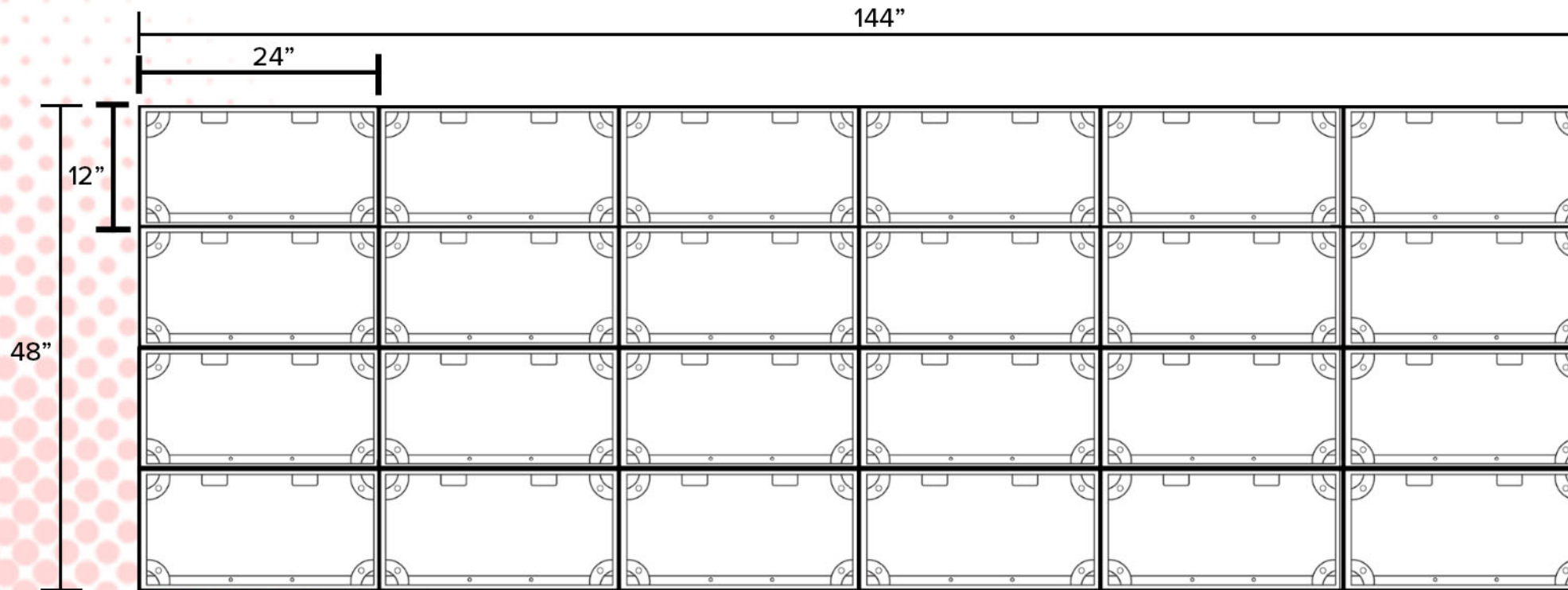

Must lift final assembled sign with a minimum of two lifting points. 330 maximum lbs per lifting pin.

Parts List	Single Face	Double Face
Module	24	48
Controller	1	1
Controller Cable Kit	1	2
Boost Power Cable	1	2

AND

Option 1: Single Frame Assembly	Single Face	Double Face
1' x 2' Frame	24	48
1' x 2' Frame Door (Optional)	24	48

OR

Option 2: Mixed Frame Assembly	Single Face	Double Face
1' x 2' Frame	0	0
1' x 2' Frame Door (Optional)	0	0
2' x 4' Frame	6	12
2' x 4' Frame Door (Optional)	12	24

## MASTER DISPLAY REAR VIEW

### SHACKLE ATTACHMENT

The shackle cables should connect to the lifting pins at an angle of 30 degrees or less to prevent damage to the cabinet frame. Spreader bar should be used when three or more lifting pins are required per face.

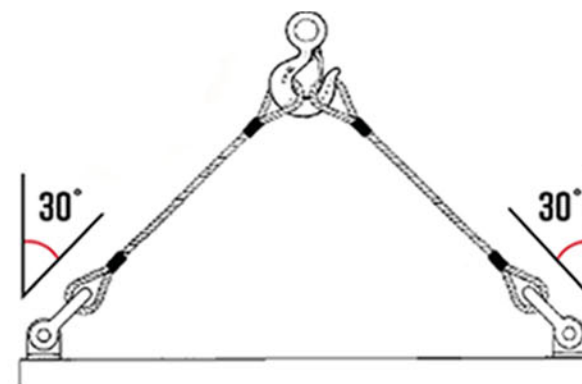

Display Weight	Maximum lbs	Maximum lbs per lifting pin	Number of Pins Per Face
Single Face	405.3	330	2
Double Face	810.6	N/A	N/A